

FAW Hazardous Area Air Warmers

The FAW range offers a versatile, lightweight air warming solution for small work and storage areas, and is suitable for use with 1 phase or 3 phase power supplies up to 660 volts. The range can also be configured for use with DC power supplies.

This range is certified for use in hazardous areas where the atmosphere is classified as a Zone 1 or 2 (IIA, IIB, IIC) gas group. When space is limited, we offer our FAW-C compact range as an option.

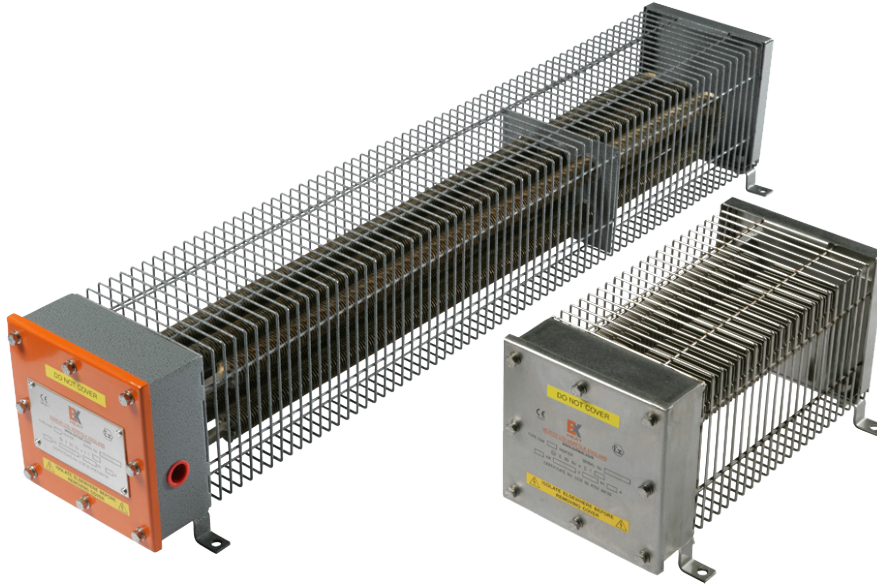

FEATURES

- Certified to ATEX, IECEx, CU TR (EAC), KGS and CSA standards
- Temperature classes T2, T3, and T4 available
- Lightweight enclosure certified weatherproof to IP67
- Suitable for 1 phase or 3 phase (3 or 4 wire) or DC power supplies
- Suitable for horizontal floor or wall mounting
- A 20mm cable entry is provided as standard, additional entries can be provided as required
- Powder coated finish on standard design / 316L Stainless Steel on compact design
- Optional range of flameproof room thermostats can also be provided
- T3 / T4 units suitable for ambient temperatures from -60°C to +40°C and T2 units to +60°C

TYPICAL APPLICATIONS

- Aircraft hangars
- Battery stores
- Chemical plants
- Container heating
- Crane / forklift cabins
- Deluge cabinet heating
- Enclosures / cabinets
- Frost protection
- Fuel servicing areas
- Gas installations
- Motor enclosures
- Offshore installations
- Paint / solvent stores
- Safety equipment enclosure
- Safety showers
- Spray booths

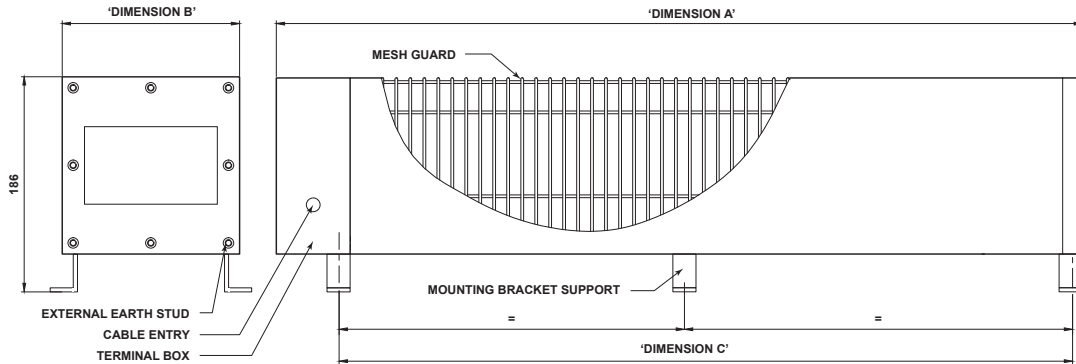

Model	T Class	Watts Rating	Voltage	Supports	Dimensions				Weight (kg)
					A (l)	B (w)	C (leg length)	D (h)	
Compact Range									
FAW-C-250	T2/T3	250	240 or 110	2	350	161	282	186	5
FAW-C-500	T2/T3	500	240 or 110	2	350	161	282	186	6
FAW-C-750	T2/T3	750	240 or 110	2	615	161	545	186	6
FAW-C-1000	T2/T3	1000	240 or 110	2	615	161	545	186	9

Model	T Class	Watts Rating	Voltage	Supports	Dimensions			Weight (kg)
					A	B	C	
Standard Range								
FAW250	T2/T3	250	240/254 or 110	2	971	161	860	8
FAW500	T2/T3	500	240/254 or 110	2	971	161	860	10
FAW750	T2/T3	750	240/254/415/440 or 110	2	971	161	860	12
FAW1000	T2/T3	1000	240/254/415/440 or 110	2	1221	161	1145	14
FAW1500	T2/T3	1500	240/254/415/440 or 110	3	1741	161	1670	20
FAW2000	T2/T3	2000	240/254 or 110	4	1741	272	1670	32
FAW2000-SB	T2/T3	2000	240/254/415/440 or 110	3	1221	272	1145	34
FAW2500	T2/T3	2500	240/254	4	1741	272	1670	38
FAW3000	T2/T3	3000	240/254/415/440	4	1741	272	1670	42
FAW250	T4	250	240/254	3	1886	161	1784	13
FAW500	T4	500	240/254	3	1886	161	1784	17
FAW750	T4	750	240/254/415/440	3	1886	161	1784	21
FAW1000	T4	1000	240/254	4	1886	272	1784	33
FAW1250	T4	1250	240/254	4	1886	272	1784	38
FAW1500	T4	1500	240/254/415/440	4	1886	272	1784	42

Certification

ATEX/IECEx Ⓢ II 2 G
 Ex e IIC T2 to T4 Gb Zone 1 and 2 (IP67)
CSA Class I, Division 2. Groups A, B, C, D. T Class T4, T3 or T2

CU TR (EAC)

1EX e II T4...T2 Gb

KGS certification available

Controls

If required, the heaters can be controlled from the EXHEAT Industrial range of remote mounted thermostats available for use in hazardous areas

Enclosure

Lightweight 304/316 stainless steel or powder coated mild steel

Mounting

Support feet are pre-drilled and suitable for floor mounting supplied as standard (wall mounting brackets available on request). The FAW-C compact design does not require separate brackets and can be wall mounted utilising the existing support feet. The heaters should be mounted horizontally with unrestricted air flow around the unit.

Rating

250W to 3kW

Voltage

1 phase: 110V to 120V and 220V to 254V

3 phase: 380V to 440V (max voltage 660V standard units and 550V compact units, subject to design parameters)

Voltage tolerance: +0/-10%