

ZONE 1 ZONE 21

SCOTIA_{Ex}



The **Scotia_{Ex}** is a low energy luminaire with an instant on output delivering 110,000 maintenance free hours at 25°C.

Its excellent temperature range of -50°C to +55°C makes it a global lighting solution providing high output lighting at extreme temperatures.

Mounting Options

- Floodlight
- Pendant
- High Bay
- Pole/Column
- Streetlighting

International Approvals



Standard Specification

Scotia_{Ex} Ex d e LED Floodlight

Type of Protection	Ex d e (Flameproof, Increased Safety) Ex tb (Dust Protected Enclosure)
ATEX Classification	Group II Category 2 GD
Area Classification	Zone 1 and Zone 21 areas to EN 60079-10-1 and EN 60079-10-2 with installation to EN 60079-14 (Gas Groups IIA, IIB and H2)
Certificate	EC Type Examination Certificate CML 14ATEX1086X IECEX Certificate of Conformity IECEX CML 14.0034X
Coding	Ex d e IIB (+ H2 option) T* Gb Ex tb IIIC T** °C Db IP6X Refer to table for T rating and Ambient
Enclosure	Aluminium Alloy LM6
Entry	2 x M20 cable entries
Termination	3 core 6mm ² max. conductor with looping
Installation	Stirrup mounting bracket
Control Gear	Electronic Driver
Colour Temperature (CCT)	5000K (Cool White)
Maintenance	M8 SKT HD Screws
Ingress Protection	IP66
Surge Protection	4kV line to line, 6kV line to earth
Electrical Supply	120-277V AC 50/60Hz 127-250V DC

Features

- ◆ Instant on crisp white light output
- ◆ Highly **Energy Efficient**
- ◆ **110,000** maintenance free hours at 25°C
- ◆ **Lower power consumption** than HID lamps
- ◆ **Low temperature applications to -50°C**

Chalmit®

LED SOLUTIONS

For Harsh & Hazardous Locations



www.chalmit.com



Harsh & Hazardous

Product design and specifications are subject to change without notice. Please check the Chalmit website for latest specifications. www.chalmit.com



MADE IN BRITAIN

Std. Cat No.	Delivered Output	Power Consumption	TClass	T°C (Dust)	Ambient °C	Weight
SCOD/07L/LE	6043 lm	90W	T6 T5	85 100	-20 to +40 -20 to +55	21kg
SCOD/08L/LE	8850 lm	105W	T6 T5	85 100	-20 to +40 -20 to +55	21kg
SCOD/11L/LE	11388 lm	110W	T6 T5	85 100	-20 to +40 -20 to +55	21kg
SCOD/12L/LE	12581 lm	125W	T6 T5	85 100	-20 to +40 -20 to +55	21kg

Note: For alternative beam options, please contact Chalmit Internal Sales.

Options - Suffix to Catalogue No.			
/M25	M25 Cable entries	/LT	Low temperature to -50°C (Gas groups IIA and IIB only)
/EP	Painted	/LT/H2	Low temperature to -50°C (Gas groups IIB and H2)*
/ADE	Amber LEDs	/P	PTFE

*H2 = Hydrogen

Accessories *Accessories should be ordered separately*

	Order Code
Wire Guard	SSCO1-0001
Anti Glare Shield	SSCO1-0002
Pole Mounting Bracket Assembly	SEVO4-0001
Swinging Jib Bracket	SSCO1-00009

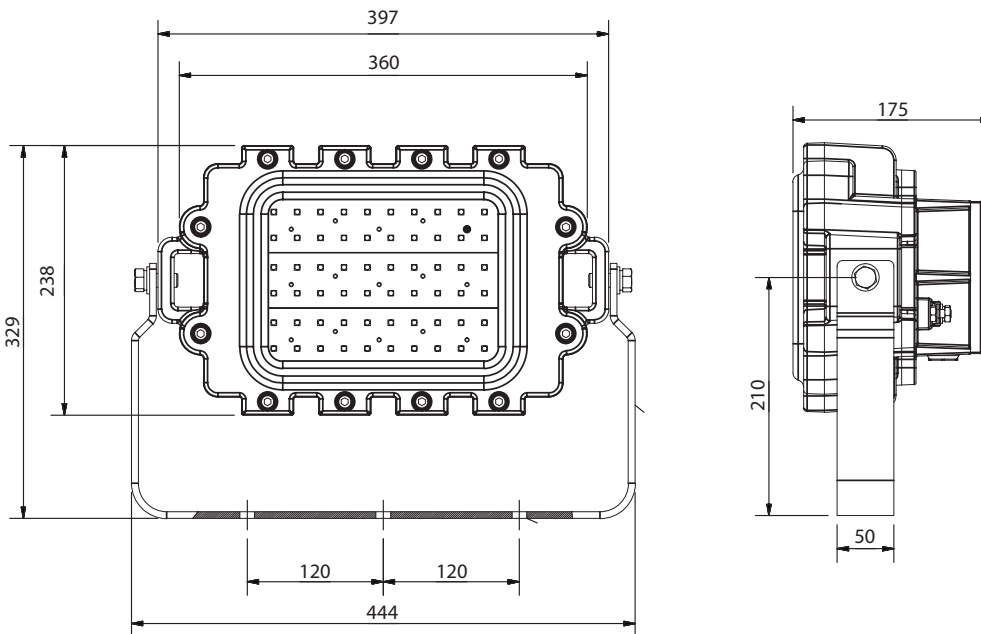

LED SOLUTIONS
 For Harsh & Hazardous Locations



Harsh & Hazardous